



May 26, 2020

Attn: Mr. Marshall Green  
Quick Mount PV  
Director of Engineering  
2700 Mitchell Dr., Bldg 2  
Walnut Creek, CA 94598

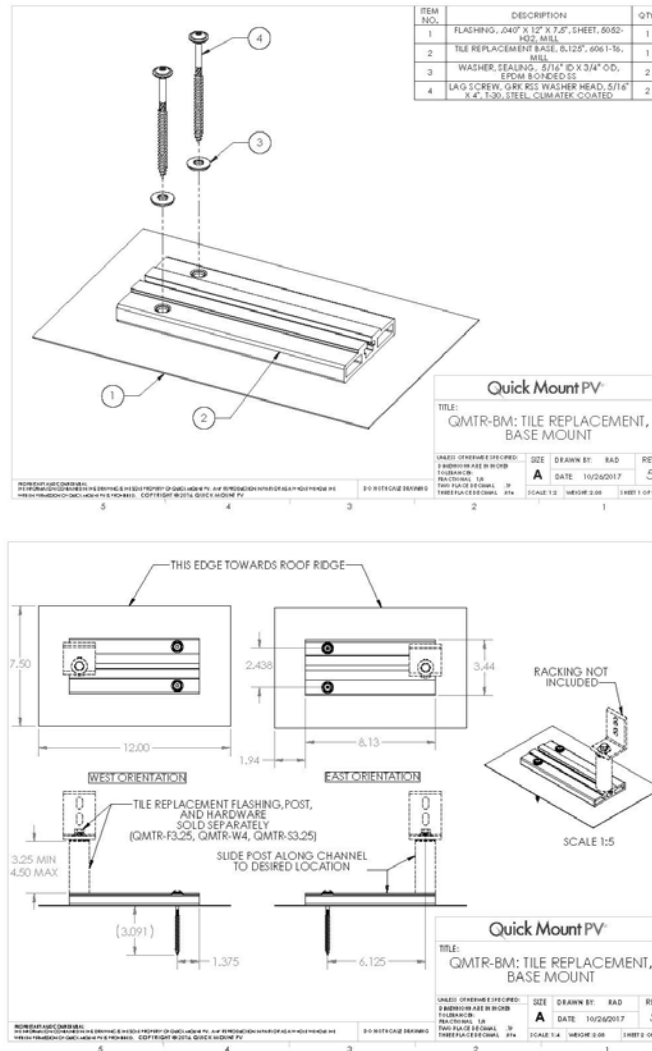
RE: Quick Mount PV Tile Replacement Mount  
Utah State Compliance Letter

SEI Project No.: 19587.00

Dear Mr. Green:

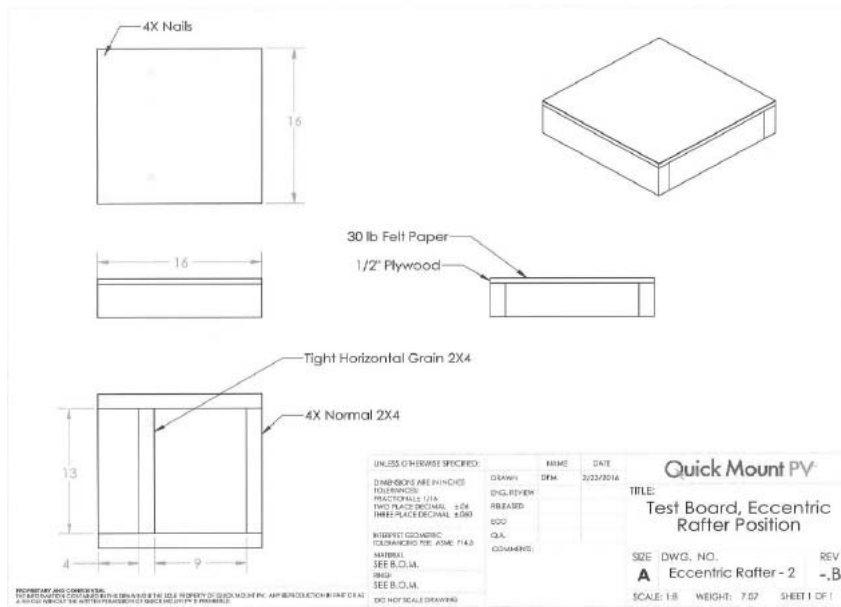
Structural Engenuity Inc. (SEI) submits this letter regarding our review of the test data for the Quick Mount PV (QMPV) Tile Replacement Mount (TRM) photovoltaic (PV) array mounting system. The test data is from the Constructive Testing Services (CTS) Test Report number 11304, titled, "Quick Mount PV Load Testing – Tile Replacement Mount [QMPV# 1-28-2016-REV C]", dated April 29, 2016 and Constructive Testing Services (CTS) Test Report number 11304, titled, "Quick Mount PV Load Testing – Tile Replacement Mount [QMPV# 1-28-2016-REV C]", dated January 6, 2017 which are available upon request from QMPV. Further testing was performed at the QMPV facility in Walnut Creek, California using alternative structural screws.

CTS is a licensed testing and engineering firm located at 2118 Rheem Drive, Pleasanton, CA 94588, where the testing of the TRM assembly was performed on February 26 thru March 5, and April 7 & 8, 2016 for the initial report. Testing for a 5.5" post option was performed between December 12, 2016 and January 6, 2017. The additional testing for the alternative screws was done on September 18 & 20, 2017 and was witnessed by Mar Structural Design, a licensed structural engineering firm. The TRM assembly is designed to support and fasten L-feet, rails, and PV modules manufactured by others to the structural roof framing through plywood or OSB sheathing and roofing material that support a tile-clad roof. Figure 1 below delineates the components of a TRM assembly.

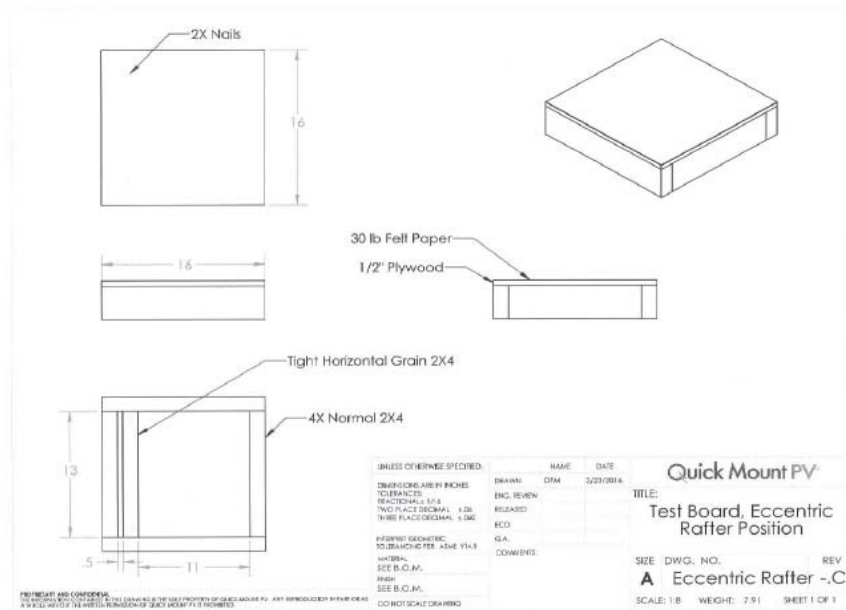


**Figure 1: TRM Assembly**

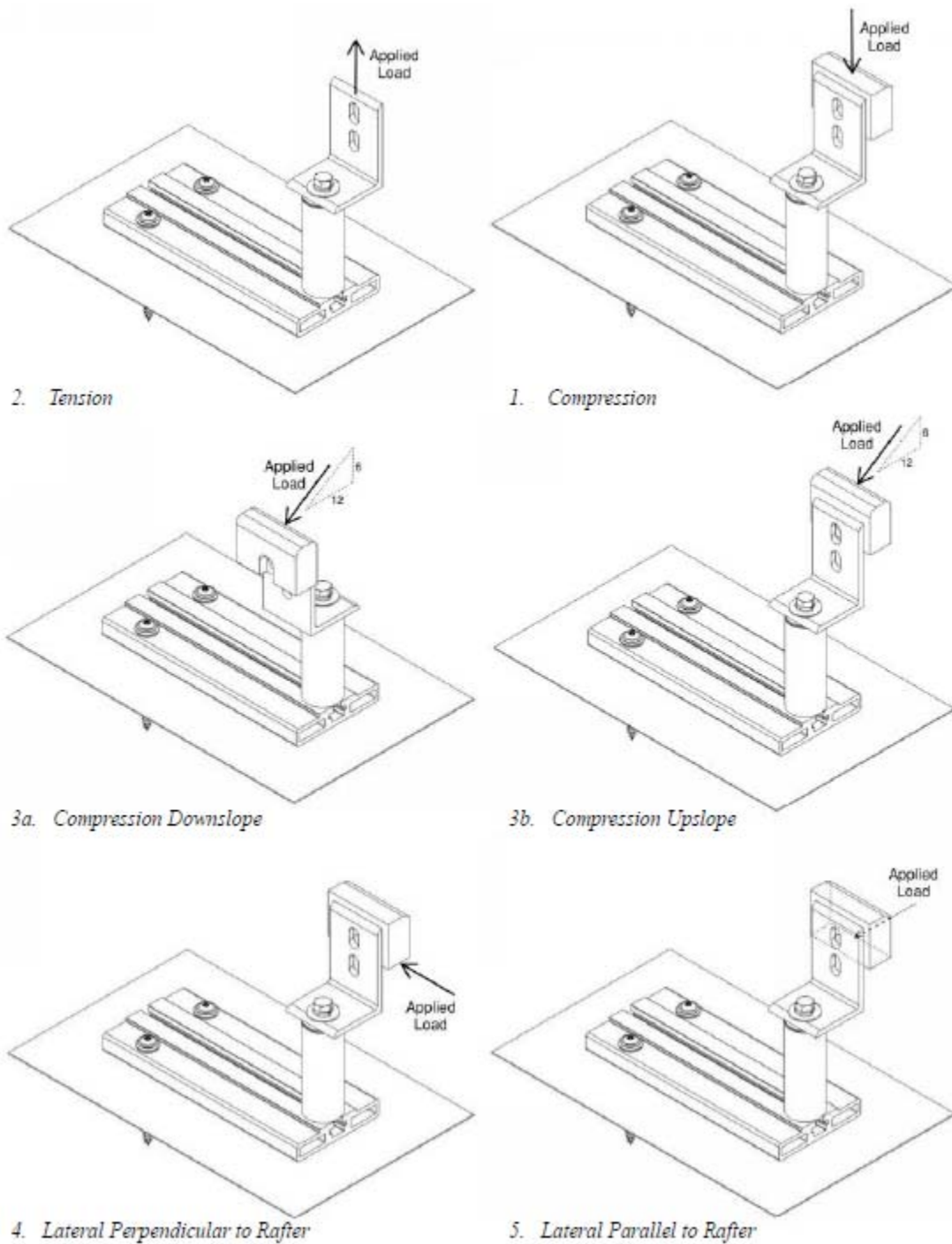
- Testing of the TRM assembly consisted of test specimens that were made up of the following:
- a wood test bed representing a plywood-sheathed, wood framed roof that comprised of 15/32" APA-rated, PS1 plywood over 2x4 Douglas Fir rafters with a moisture content of 11 to 13% (See Figure 2a and 2b for test board configurations of the various specimens being tested),
  - a QPMV TRM base mount and flashing attached with (2) 5/16" x 4" long Structural Screws, either GRK RSS Structural Screws or QMPV Button Head Structural Screws are acceptable
  - a conventional L-foot (UNIRAC product that is representative of a typical clip angle attachment commonly used in the solar industry) with a metal block attached to the L-foot to represent the rail that the PV modules are fastened to that cause an eccentric load onto the QPMV TRM. See Figure 3 for the Loading Configurations for the various tests applied to the specimens. It should be noted that the metal block is not used in every test.
  - A compression test was done without the L-foot attached in order to determine the plywood limit state.



**Figure 2a: Tension Test Board Configuration**



**Figure 2b: Test Board Configuration For All Other Tests**



**Figure 3: Loading Configurations of Each Test by CTS**

The tests, with loadings applied as shown above, were created to simulate the reactions that would be applied to the L-foot bracket connection of the QMPV TRM due to the environmental loads projected on a PV solar roof array that is fastened to a roof by the QMPV TRM system. The tests were simulated for the environmental loads as follows:

- Tension test simulated wind uplift that was normal to the slope of the roof minus self-weight of the PV modules,
- Compression test simulated a low-slope roof condition and a steeper 6:12 slope condition. The low-slope roof compression test simulated a snow and array self-weight vertically down plus wind down normal to the slope of the roof. The 6:12 roof slope compression test with snow load parallel to roof slope being greatest simulated load applied with L-foot mounted on the upslope, as well as on the downslope side of the post to account for worst case eccentric loading.
- Lateral parallel to rafter simulated parallel to roof force component of downward snow and self-weight loads,
- Lateral perpendicular to rafter test simulated seismic loads on the cross-slope direction of the roof.

Tests were conducted such that the post was positioned on the base track at the furthest setting point from the structural screw connections in order to test the TRM base mount at its worst case for all loading conditions. While the post length is available in 3.25", 4", 4.5", & 5.5" options, the test specimens used the longest available post length in order to test the QMPV TRM under its most extreme layout for conservative results regarding its allowable capacities and serviceability deflections. Therefore, it should be noted that the CTS Test Report does not quantify the strengthening effect of using a smaller post length or positioning of the post on the base mount closer to the structural screw connection.

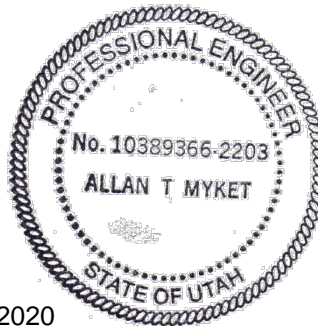
The evaluation was limited to the components of the Tile Replacement Mount that is manufactured by Quick Mount PV with test specimens installed conformance with Quick Mount PV's product installation manual and specifications. Elements of the test specimen that are not manufactured by Quick Mount PV, such as the L-foot bracket and roof rafter capacity were not evaluated in SEI's evaluation of the QMPV TRM product; therefore, load capacities of these external elements should be determined by others or referenced by test data provided by the manufacturers of these elements. The following tables attached to this letter list the combined results of the six applied test load directions from the CTS Test Report, allowable stress design (ASD) capacities extrapolated from the test results using ASD load combinations listed in ASCE for conformance with the 2018 International Building Code and 2018 International Residential Code for verifying capacity of the Quick Mount PV Tile Replacement Mount to be used as a faster for roof mounted PV Solar Arrays on tile covered roofs in the state of Utah.

Should you have any questions relating to this matter please contact me at your convenience.

Sincerely,



Allan T. Myket, P.E.  
President/Founder  
[amyket@structuralengenuityinc.com](mailto:amyket@structuralengenuityinc.com)



**Structural Engenuity Inc.**

06/01/2020

**Table 1: Summary of Allowable Loads for Quick Mount PV® Tile Replacement Mount (4.5" Post) CTS Test Report Results**

Loading Condition	Mean Tested Peak Load (lbs)	Minimum Tested Peak Load (lbs)	No. of Tests	Type of Failure	FS: Method of Calculation	Factor of Safety	Allowable Load (lbs)
Tension	1403	989	12	bolt track fracture/steel bolt fracture/lag	Aluminum Design Manual, 2015	2.25	623
Compression Plywood Limit State	2791	2587	3	plywood	AC13	3.00	862
Compression L-Foot Limit State	1148	1083	4	L-foot alum bending	Aluminum Design Manual, 2015	1.74	660
Compression at 6:12 L-Foot Downslope Position	438	430	4	L-foot alum bending	Aluminum Design Manual, 2015	1.65	266
Compression at 6:12 L-Foot Upslope Position	1881	1815	4	L-foot alum bending / plywood	AC13	3.00	605
Lateral Parallel (Down-Slope)	439	433	4	alum bending and crushing	Aluminum Design Manual, 2015	2.22	197
Lateral Perpendicular (Cross-Slope)	377	351	6	alum bending	Aluminum Design Manual, 2015	2.06	183

Factor of Safety Calculation Methods:

Aluminum Design Manual, 2015, Appendix 1: Testing, 1.3.2 Tests for Determining Structural Performance, Eq. 1.3-3

AC13: ICC Acceptance Criteria 13. Minimum failure load from three tests, divided by 3. Duration Factor for bearing used = 1.0.

Material Notes:

The Quick Mount PV Tile Replacement Flashing Mount Parts observed in tests to failure modes as noted above.

Post = 6063-T5 (T6 is also acceptable)

Base = 6061-T6 (6005A-T61 & 6005-T5 are also acceptable)

Structural Screws = 5/16" x 4" long GRK Structural Screws or 5/16" x 4" long QMPV Button Head Structural Screws

Test Loading Notes:

1. Rafters used in samples comprised of Douglas Fir-Larch (G=0.5). Wood species and grade used that differs from this may cause structural screw pull-out to occur sooner; therefore, adjustment of the tabulated allowable values is done based on the specific gravity of the other species of wood. In no circumstance shall the allowable loads given in the above table be increased due to a higher value of Specific Gravity than what was present in the test data. The 2018 NDS equation 12.2-1:  $(G1/G2)^2$ , results in the following adjustment factors:

Alaska Yellow Cedar (G=0.46) - Multiply allowable values by 0.85

Hem-Fir and Spruce-Pine-Fir (G=0.42) - Multiply allowable values by 0.70

Open-Grained Redwood and Western Cedar (G=0.36) - Multiply allowable values by 0.52

2a. Downward load was applied directly to the top of the post to determine compression limit state.

2b. Downward load was applied to a block representative of typical load transfer from the rail into the L-foot. Foot yielded in bending before mount assembly or plywood sheathing failed. This allowed capacity varies according to L-foot used.

3a. Vertical load was applied to the assembly on a slope with, the back of the L-foot facing down-slope. This allowable capacity may vary according to L-foot used.

3b. Vertical load was applied to the assembly on a slope, with the back of the L-foot facing up-slope. This allowable capacity may vary according to L-foot used.

4. Load is applied perpendicular to rafter. Represents the cross-slope parallel-to-roof force component of seismic loads.

5. Load is applied parallel to rafter. Represents the downslope parallel-to-roof force component of gravity (snow & self weight) loads. Under actual snow load conditions, loads perpendicular-to-roof occur simultaneously, and typically increase allowable loads and decrease deflections. See, for instance, the load cases 3a and 3b for 6:12 roof slopes, the slope where the code snow parallel-to-roof force component is greatest.

6. Allowable Load Table is based on a minimum thread embedment of 2-1/2", including the tip, into the structural member for each structural screw. If less embedment is achieved, loads should be adjusted accordingly.

**Table 2: Service Load Deflection at Top of Assembly**

Loading Condition	Allowable Load (lbs)	Service Load (lbs)	Service Deflection (in)
Tension	623	436	0.57
Compression Plywood Limit State	862	862	0.22
Compression L-Foot Limit State	660	462	0.24
Compression at 6:12 L-Foot Downslope Position	266	186	0.47
Compression at 6:12 L-Foot Upslope Position	605	424	0.26
Lateral Parallel (Down-Slope)	197	138	0.82
Lateral Perpendicular (Cross-Slope)	183	128	0.37

Note: Refer to Table 1 for footnotes regarding factors of safety, loading conditions, and materials

Serviceability Data Notes:

1. Service deflections are measured at the point of applied load, typically at the top of the L-foot, & is measured in the direction of the applied load.
2. Deflections are reported for the longest post located farthest from the structural screws. The use of shorter posts and/or placement of the posts closer to the structural screws may substantially reduce deflections.
3. Service deflection is the average of test deflections at service load.
4. Service load typically matches allowable load. For Load Case 1, tension up caused by wind uplift, service load is 70% of allowable load per ICC deflection criteria.

**Table 3: Summary of Allowable Loads for Quick Mount PV® Tile Replacement Mount (5.5" Post) CTS Test Report Results**

Loading Condition	Mean Tested Peak Load (lbs)	Minimum Tested Peak Load (lbs)	No. of Tests	Type of Failure	FS: Method of Calculation	Factor of Safety	Allowable Load (lbs)
Tension <sup>6</sup>	1403	989	12	bolt track fracture/steel bolt fracture/lag	Aluminum Design Manual, 2015	2.25	623
Compression Plywood Limit State <sup>6</sup>	2791	2587	3	plywood	AC13	3.00	862
Compression L-Foot Limit State <sup>6</sup>	1117	1083	4	L-foot alum bending	Aluminum Design Manual, 2015	1.74	660
Compression at 6:12 L-Foot Downslope Position	433	419	6	L-foot alum bending	Aluminum Design Manual, 2015	1.63	266
Compression at 6:12 L-Foot Upslope Position	1829	1705	4	L-foot alum bending	AC13	3.00	568
Lateral Parallel (Down-Slope)	366	351	4	alum bending and crushing	Aluminum Design Manual, 2015	1.87	195
Lateral Perpendicular (Cross-Slope)	344	309	5	Post Crushing, Bolt Fractured	Aluminum Design Manual, 2015	2.03	169

**Factor of Safety Calculation Methods:**

Aluminum Design Manual, 2015, Appendix 1: Testing, 1.3.2 Tests for Determining Structural Performance, Eq. 1.3-3

AC13: ICC Acceptance Criteria 13. Minimum failure load from three tests, divided by 3. Duration Factor for bearing used = 1.0.

**Material Notes:**

The Quick Mount PV Tile Replacement Flashing Mount Parts observed in tests to failure modes as noted above.

Post = 6063-T5 (T6 is also acceptable)

Base = 6061-T6 (6005A-T61 & 6005-T5 are also acceptable)

Structural Screws = 5/16" x 4" long GRK Structural Screws or 5/16" x 4" long QMPV Button Head Structural Screws

**Test Loading Notes:**

1. Rafters used in samples comprised of Douglas Fir-Larch (G=0.5). Wood species and grade used that differs from this may cause structural screw pull-out to occur sooner; therefore, adjustment of the tabulated allowable values is done based on the specific gravity of the other species of wood. In no circumstance shall the allowable loads given in the above table be increased due to a higher value of Specific Gravity than what was present in the test data. The 2018 NDS equation 12.2-1:  $(G1/G2)^2$ , results in the following adjustment factors:

Alaska Yellow Cedar (G=0.46) - Multiply allowable values by 0.85

Hem-Fir and Spruce-Pine-Fir (G=0.42) - Multiply allowable values by 0.70

Open-Grained Redwood and Western Cedar (G=0.36) - Multiply allowable values by 0.52

2a. Downward load was applied directly to the top of the post to determine compression limit state.

2b. Downward load was applied to a block representative of typical load transfer from the rail into the L-foot. Foot yielded in bending before mount assembly or plywood sheathing failed. This allowed capacity varies according to L-foot used.

3a. Vertical load was applied to the assembly on a slope with, the back of the L-foot facing down-slope. This allowable capacity may vary according to L-foot used.

3b. Vertical load was applied to the assembly on a slope, with the back of the L-foot facing up-slope. This allowable capacity may vary according to L-foot used.

4. Load is applied perpendicular to rafter. Represents the cross-slope parallel-to-roof force component of seismic loads.

5. Load is applied parallel to rafter. Represents the downslope parallel-to-roof force component of gravity (snow & self weight) loads. Under actual snow load conditions, loads perpendicular-to-roof occur simultaneously, and typically increase allowable loads and decrease deflections. See, for instance, the load cases 3a and 3b for 6:12 roof slopes, the slope where the code snow parallel-to-roof force component is greatest.

6. Loading Condition Information is based on Original testing using 4.5" long post and structural analysis to determine that increased 5.5" post has no affect on capacity

7. Results provided in table are based on controlling cases between Original Test Data and New Test Data

8. Allowable Load Table is based on a minimum thread embedment of 2-1/2", including the tip, into the structural member for each structural screw. If less embedment is achieved, loads should be adjusted accordingly.



**Table 4: Service Load Deflection at Top of Assembly (5.5" Post)**

Loading Condition	Allowable Load (lbs)	Service Load (lbs)	Service Deflection (in)
Tension <sup>6</sup>	623	436.1	0.57
Compression Plywood Limit State <sup>6</sup>	862	862	0.22
Compression L-Foot Limit State <sup>6</sup>	660	660	0.24
Compression at 6:12 L- Foot Downslope Position	266	266	0.66
Compression at 6:12 L- Foot Upslope Position	568	568	0.32
Lateral Parallel (Down- Slope)	195	195	0.93
Lateral Perpendicular (Cross-Slope)	169	169	0.67

Note: Refer to Table 1 for footnotes regarding factors of safety, loading conditions, and materials

Serviceability Data Notes:

1. Service deflections are measured at the point of applied load, typically at the top of the L-foot, & is measured in the direction of the applied load.
2. Deflections are reported for the longest post located farthest from the GRK screws. The use of shorter posts and/or placement of the posts closer to the GRK screws may substantially reduce deflections.
3. Service deflection is the average of test deflections at service load.
4. Service load typically matches allowable load. For Load Case 1, tension up caused by wind uplift, service load is 70% of allowable load per ICC deflection criteria.