

January 22, 2020

Attn: Mr. Marshall Green  
Quick Mount PV  
Director of Engineering  
2700 Mitchell Dr., Bldg 2  
Walnut Creek, CA 94598

RE: Quick Mount PV QBlock  
State of Connecticut Certification Letter

SEI Project No.: 19582.00

Dear Mr. Green:

Structural Enginuity Inc. (SEI) submits this letter regarding our review of the test data for the Quick Mount PV (QMPV) QBlock (QMSE, QMSC, and QMLC, QMSE-LAG, QMSC-LAG, and QMLC-LAG) photovoltaic (PV) array mounting brackets. The QBlock mounting bracket consists of an aluminum spacer block, a flashing plate, and a single fastener. The fastener used with the QMSE, QMSC, and QMLC versions is a hanger bolt, while the fastener used with the QMSE-LAG, QMSC-LAG, and QMLC-LAG versions is a lag screw.

The review was based on the following reference data:

- Applied Materials & Engineering, Quick Mount PV Load Testing, Project Number 108443C, May 22, 2009
- Applied Materials & Engineering, Laboratory Load Testing of the QMSE-Lag, Project Number 114490C, October 29, 2014

AME is a licensed testing and engineering firm located in California, where the testing of the QBlock assembly was performed. The QBlock assembly is designed to support and fasten rails and PV modules manufactured by others to the structural roof framing through plywood or OSB sheathing and roofing material consisting of composition shingles. Figure 1 below delineates the components of the QBlock assembly.

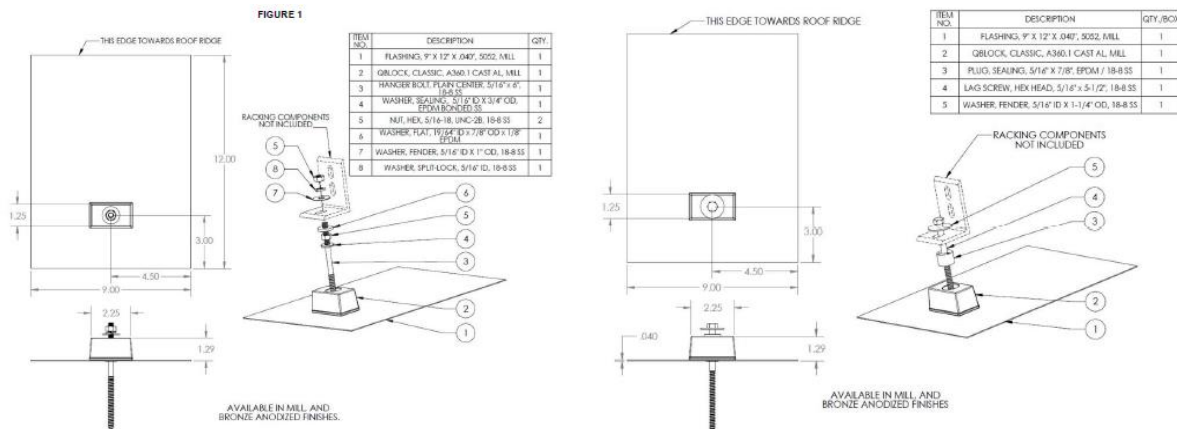

**FIGURE 1: QBlock Assembly**

Testing of the QBlock assembly consisted of test specimens that were made up of the following:

- a wood test bed representing a composition shingle, wood framed roof that is comprised of 1/2" plywood APA rated Structural I sheathing over 16" long 2"x4" rafters covered with felt paper and composition shingles. Separate test beds with either Douglas Fir or Cedar rafters were used,
- a QPMV QBlock bracket attached to rafters using one 5/16"Ø fastener with a minimum penetration of 2-7/8" into the structural members,

The test procedures were created to simulate the reactions that would be applied to the QBlock assembly due to the environmental loads projected on a PV solar roof array that is fastened to a roof by the QBlock system. The tests were simulated for the environmental loads as follows:

- Tension load test simulated wind uplift that was normal to the slope of the roof minus self-weight of the PV modules,
- Lateral load parallel to rafter simulated parallel to roof force component of downward snow and self-weight loads,

The evaluation was limited to the components of the QBlock that are manufactured by Quick Mount PV with test specimens installed in conformance with Quick Mount PV's product installation manual and specifications. Elements of the test specimen that are not manufactured by Quick Mount PV, such as the roof rafters, rails, and PV modules, were not analyzed in SEI's evaluation of the QMPV QBlock product; therefore, load capacities of these external elements should be determined by others or referenced by test data provided by the manufacturers of these elements. The following tables list the allowable loads determined from the combined results from the AME Test Reports, in conformance with the 2018 International Building Code and International Residential Code as the for verifying capacity of the Quick Mount PV QBlock to be used as a fastener for roof mounted PV Solar Arrays in the state of Connecticut. No additional load duration factors may be applied to these values.

Should you have any questions relating to this matter please contact me at your convenience.

Sincerely,



Peter Martin  
Engineer III  
[pmartin@structuralengenuityinc.com](mailto:pmartin@structuralengenuityinc.com)



Allan T. Myket, P.E.  
President/Founder  
[amyket@structuralengenuityinc.com](mailto:amyket@structuralengenuityinc.com)

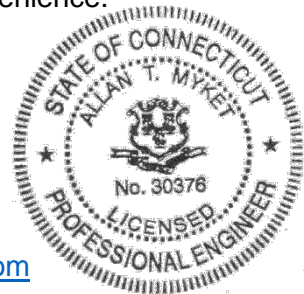

**Structural Engenuity, Inc.**

02/03/2020

**Table 1: Summary of Allowable Loads for Quick Mount PV QBlock (QMSE, QMSC, & QMLC)**

Loading Condition	Mean Tested Peak Load (lbs)	Minimum Tested Peak Load (lbs)	No. of Tests	Rafter Avg Specific Gravity	Type of Failure	FS: Method of Calculation	Factor of Safety	Allowable Load (lbs)
Tension	2554	2434	3	0.5 (Douglas Fir-Larch)	Lag Bolt Pullout	NDS, 2018	2.5, Note 3	1021 Note 1,4
	1355	1309	3	0.36 (Western Cedars)	Lag Bolt Pullout	NDS, 2018	2.5, Note 3	542 Note 1,4
Lateral (Parallel to Rafter)	2203	2012	3	0.5 (Douglas Fir-Larch)	Bent Lag Bolt	AC13	3.00	670 Note 4
	1957	1903	3	0.36 (Western Cedars)	Bent Lag Bolt	AC13	3.00	634 Note 4

**Table 2: Summary of Allowable Loads for Quick Mount PV QBlock (QMSE-Lag, QMSC-Lag, & QMLC-Lag)**

Loading Condition	Mean Tested Peak Load (lbs)	Minimum Tested Peak Load (lbs)	No. of Tests	Rafter Avg Specific Gravity	Type of Failure	FS: Method of Calculation	Factor of Safety	Allowable Load (lbs)
Tension	2197	2100	6	0.5 (Douglas Fir-Larch)	Lag Screw Pullout	NDS, 2018	2.5, Note 3	878 Note 1,4
Lateral (Parallel to Rafter)	1578	1321	6	0.5 (Douglas Fir-Larch)	Lag Screw Failure	AC13	3.00	526 Note 4

Factor of Safety Calculation Methods:

National Design Specification (NDS) for Wood Construction, 2018  
Acceptance Criteria - Joist Hangers and Similar Devices (AC13)

Material Notes:

The Quick Mount PV QBlock Mount Parts observed in tests to failure modes as noted above.  
QBlock = Cast A360 Aluminum

Test Loading Notes:

1. Rafters used in samples comprised of Douglas Fir-Larch (G=0.50). Wood species and grade used that differs from this may cause lag screw pull-out to occur sooner; therefore, adjustment of the tabulated allowable values is done based on the specific gravity of the other species of wood. The tabulated values shall not be adjusted by a factor greater than 1. The 2015 NDS equation 12.2-1:  $(G1/G2)^{1.5}$ , results in the following:

Alaska Yellow Cedar (G=0.46) - Multiply allowable values by 0.88

Hem-Fir and Spruce-Pine-Fir (G=0.42) - Multiply allowable values by 0.77

Open-Grained Redwood and Western Cedar (G=0.36) - Multiply allowable values by 0.61

2. All loads were applied to an attached L-Foot.

3. Per the NDS, a safety factor of 4 has been applied. The resulting allowable load has been multiplied by a load duration factor of 1.6 for Wind and Seismic load conditions for Tension load cases and a factor of 1.15 for Snow load conditions for Lateral loads parallel to rafters per section 10.3.2 in the NDS for Wood Construction. No further load duration factors may be applied.

4. Allowable load tables are based on a minimum screw penetration of 2-7/8" into the structural member. If less penetration is achieved, loads should be adjusted accordingly.