



April 13, 2020

Attn: Mr. Marshall Green
Quick Mount PV
Director of Engineering
2700 Mitchell Dr., Bldg 2
Walnut Creek, CA 94598

RE: Quick Mount PV QBase
State of Oregon Certification Letter

SEI Project No.: 19583.00

Dear Mr. Green:

Structural Enginuity Inc. (SEI) submits this letter regarding our review of the test data for the Quick Mount PV (QMPV) QBase (QMNC, QMUTM, QMSFT, QMNS, and QMLSH in 3.75, 5, 7, 9 & 12" heights) photovoltaic (PV) array mounting brackets. The QBase mounting bracket consists of an aluminum post of varying height, a cast aluminum base, a connecting screw, and two wood lag screws.

The review was based on the following reference data:

- Applied Materials & Engineering, New Construction Composition Mount (QMNC 3-3/4" Finished Height) Load Testing, Project Number 111114C, March 23, 2011
- Applied Materials & Engineering, Low Slope Mount QMLS-9 Hardware Load Testing, Project Number 111203C, May 5, 2011
- Applied Materials & Engineering, Low Slope Mount QMLS-12 Hardware Load Testing, Project Number 111204C, May 9, 2011
- Applied Materials & Engineering, Low Slope Mount QMLS-7 Hardware Load Testing, Project Number 111316C, July 5, 2011
- Applied Materials & Engineering, Quick Mount QBase with 4.5" Post as Used in Low Slope Mount (QMLSH-5) & Standard Flat Tile Mount (QMSFT) Load Testing, Project Number 111204C, March 23, 2020

AME is a licensed testing and engineering firm located in California, where the testing of the QBase assembly was performed. The QBase assembly is designed to support and fasten rails and PV modules manufactured by others to the structural roof framing through plywood or OSB sheathing and a variety of roofing materials including TPO, PVC, EPDM, built-up roofing, composition shingles, tile, shake, and slate. Figure 1 below delineates the components of the QBlock assembly.

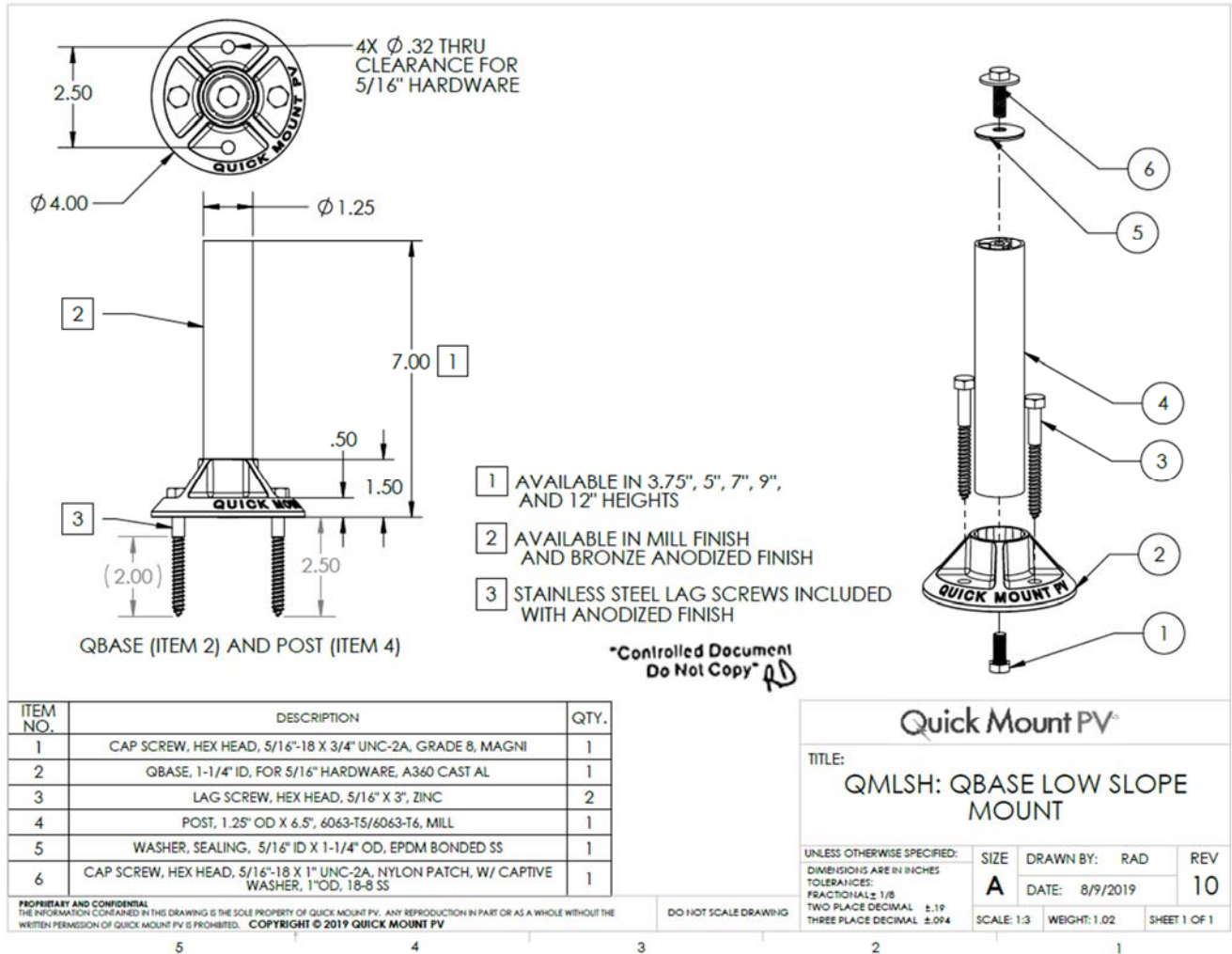

FIGURE 1: QBase Assembly

Testing of the QBase assembly consisted of test specimens that were made up of the following:

- a wood test bed representing a wood framed roof that is comprised of 1/2" plywood APA rated Structural I sheathing over 16" long 2"x4" rafters covered with roofing paper.
- a QPMV QBase bracket attached to rafters using two 5/16"Ø x 3" lag screws with a minimum penetration of 2" into the structural members,

The test procedures were created to simulate the reactions that would be applied to the QBase assembly due to the environmental loads projected on a PV solar roof array that is fastened to a roof by the QBlock system. The tests were simulated for the environmental loads as follows:

- Tension load test simulated wind uplift that was normal to the slope of the roof minus self-weight of the PV modules,
- Lateral load parallel to the rafters simulated parallel to roof force component of downward snow and self-weight loads,
- Lateral load perpendicular to the rafters simulated perpendicular to roof force component of seismic loads,

The evaluation was limited to the components of the QBase that are manufactured by Quick Mount PV with test specimens installed in conformance with Quick Mount PV's product installation manual and specifications. Elements of the test specimen that are not manufactured by Quick Mount PV, such as the roof rafters, rails, and PV modules, were not analyzed in SEI's evaluation of the QMPV QBase product; therefore, load capacities of these external elements should be determined by others or referenced by test data provided by the manufacturers of these elements. The following tables list the allowable loads determined from the combined results from the AME Test Reports, in conformance with the 2018 International Building Code and International Residential Code for verifying capacity of the Quick Mount PV QBase to be used as a fastener for roof mounted PV Solar Arrays in the state of Oregon. No additional load duration factors may be applied to these values.

Should you have any questions relating to this matter please contact me at your convenience

Sincerely,



Peter Martin
Engineer III

pmartin@structuralenginuityinc.com

Structural Enginuity, Inc.

Mark A. Tryon, P.E.

Vice-President/Founder

mtryon@structuralenginuityinc.com



EXPIRES: 06/30/2020

04/27/2020

Table 1

Allowable Loads for Quick Mount PV QBase (QMNC, QMUTM, QMSFT, QMNS, & QMLSH)

Loading Condition	Finished Height of Mount	Mean Tested Peak Load (lbs)	Minimum Tested Peak Load (lbs)	No. of Tests	Allowable Load (lbs)
Tension	All Mounts	3031	2807	3	936
Lateral (Parallel to Rafter)	3.75"	1972	1848	3	616
	5"	1418	1397	3	466
	7"	803	670	3	223
	9"	763	753	3	251
	12"	519	484	3	161
Lateral (Perpendicular to Rafter)	3.75"	1466	1286	3	429
	5"	1024	956	3	319
	7"	583	500	3	167
	9"	579	516	3	172
	12"	377	330	3	110

Factor of Safety Calculation Methods:

Safety Factor of 3.0 is used in all cases per Acceptance Criteria - Joist Hangers and Similar Devices (AC13)

Material Notes:

The Quick Mount PV QBlock Mount Parts observed in tests to failure modes as noted above.

QBase = Cast A360 Aluminum

Post = 6063-T5/6063-T6 Aluminum

Test Loading Notes:

1. Rafters used in samples comprised of Douglas Fir with specific gravity averaging 0.45. Wood species and grade used that differs from this may cause lag screw pull-out to occur sooner; therefore, adjustment of the tabulated allowable values is done based on the specific gravity of the other species of wood. The tabulated values shall not be adjusted by a factor greater than 1. The 2015 NDS equation 12.2-1: $(G1/G2)^{1.5}$, results in the following:

Hem-Fir and Spruce-Pine-Fir (G=0.42) - Multiply allowable values by 0.77

Open-Grained Redwood and Western Cedar (G=0.36) - Multiply allowable values by 0.61

2. Allowable load tables are based on a minimum screw penetration of 2" into the structural member. If less penetration is achieved, loads should be adjusted accordingly.

3. Observed failure modes as follows:

Tension: Lag pullout

Lateral Parallel to Rafter: Lag pullout & aluminum fracture

Lateral Perpendicular to Rafter: Plywood bearing damage & bolt yielding