

# Universal Tile Mount | QMUTM

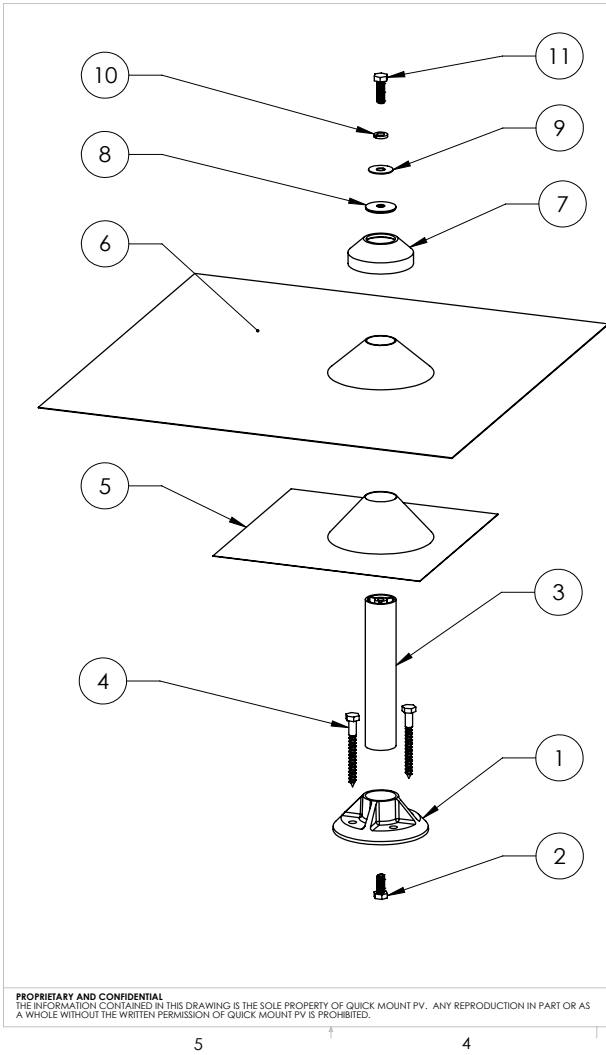

ITEM NO.	DESCRIPTION	QTY.
1	Low Slope QBase, Cast AL	1
2	Hex Bolt, 5/16" x 3/4", Grade 8	1
3	Post, 1.25" OD x 6.5", 8.5", or 11.5", AL*	1
4	Lag Screw, Hex Head, 5/16" X 3", Zinc	2
5	QBase Primary flashing	1
6	Flashing, Spun Cone, 18"x18"x.032"x1.46" Cone*	1
7	EPDM Rubber Counter Flashing	1
8	Washer, Sealing, 5/16" ID x 1-1/8" OD, SS/EPDM	1
9	Washer, Fender, 5/16" X 1", SS	1
10	Washer, Split-Lock, 5/16", SS	1
11	Hex Bolt, 5/16" x 1", SS	1

\*Available in mill, clear anodized, and dark bronze anodized finishes.

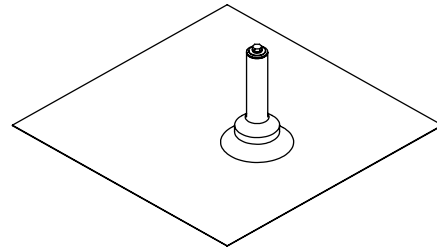

Quick Mount PV

TITLE:  
QMUTM:  
Universal Tile Mount

UNLESS OTHERWISE SPECIFIED: DIMENSIONS ARE IN INCHES TOLERANCES: FRACTIONAL ± 1/16 TWO PLACE DECIMAL ±.01 THREE PLACE DECIMAL ±.005	SIZE <b>A</b>	DRAWN BY: JDA DATE: 2/22/2012	REV <b>2</b>
SCALE: 1:8		WEIGHT: 1.98	SHEET 1 OF 2

PROPRIETARY AND CONFIDENTIAL  
THE INFORMATION CONTAINED IN THIS DRAWING IS THE SOLE PROPERTY OF QUICK MOUNT PV. ANY REPRODUCTION IN PART OR AS A WHOLE WITHOUT THE WRITTEN PERMISSION OF QUICK MOUNT PV IS PROHIBITED.

DO NOT SCALE DRAWING

5

4

3

2

1

## Lag pull-out (withdrawal) capacities (lbs) in typical lumber:

	Lag Bolt Specifications		
	Specific Gravity	2/ea 5/16" shaft per 2.5" thread depth	5/16" shaft per 1" thread depth
Douglas Fir, Larch	.50	1330	266
Douglas Fir, South	.46	1175	235
Engelmann Spruce, Lodgepole Pine (MSR 1650 f & higher)	.46	1175	235
Hem, Fir	.43	1060	212
Hem, Fir (North)	.46	1175	235
Southern Pine	.55	1535	307
Spruce, Pine, Fir	.42	1025	205
Spruce, Pine, Fir (E of 2 million psi and higher grades of MSR and MEL)	.50	1330	266

Sources: American Wood Council, NDS 2005, Table 11.2 A, 11.3.2 A

### Notes:

- 1) Thread must be embedded in a rafter or other structural roof member.
- 2) See IBC for required edge distances.

**Important:** To maintain waterproofing of substrate it is important to make sure the aluminum primary flashing is properly placed over the QBase and under the course of paper above. If the paper above does not reach, due to layout, place an additional piece of roofing paper over the primary flashing and under the next course of paper above. (See instructions on reverse)



# Quick Mount PV<sup>®</sup>

## Universal Tile Mount - Instructions for Rafter Installation

**WARNING:** Quick Mount PV products are NOT designed and should NOT be used to anchor fall protection equipment.



Remove tile at selected location of mount.



Locate and mark center of rafter.



Use a straight edge and measure up 6 5/8" from bottom of tiles to center of the mount over the center of rafter.



Align QBase over rafter center and drill two 7/32" pilot holes. Place grade-8 machine bolt under QBase in hex slot, threads pointing up. Lag QBase into rafter on marks.



Carefully clean the building paper then install primary flashing in either a three-course method or properly lapped paper method.\* Apply bead of sealant in the shape of an upside down U on the back side of the sub-flashing.



Take care to do a quality installation. When using the paper method, cut a piece of paper 18" wide to slide under the course above, and over the primary flashing of the mount.



Cut a hole in the tile removed, with room to get the post through. Replace tile in position. Insert post and tighten into place. Install the 18"x 18" flashing and apply sealant around the opening.

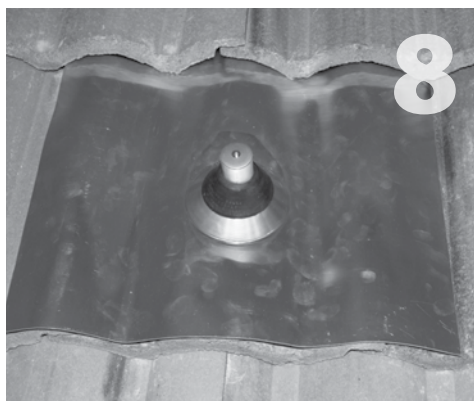

Pre-bend the flashing to follow the contour of the tile if curved. Apply sealant where post and flashing meet, and install counter flashing collar. (Be sure to seal off the post from weather exposure with the sealing washer (item 8), in the interim before racks are installed.)

You are now ready for the rack of your choice. Follow all the directions of the rack manufacturer as well as the module manufacturer.

All roofing manufacturers' written instructions must also be followed by anyone modifying a roof system. Please consult the roof manufacturer's specs and instructions prior to touching the roof.

\* For more details on underlayment waterproofing please visit our website: <http://www.quickmountpv.com/products/universal-tile-mount.html>

# Universal Tile Mount | QMUTM

## Additional Dimensions

